

FILE NAME : SPECIFICATIONS OF
SEALED LiFePO₄
CYLINDRICAL BATTERIES

MODEL : **IFR18650-1500mAh**

Specification No.: S/RONDA1403-1

EDITION : A 0

DATE : **2011-12-22**

EDITION	AMENDMENT		DATE OF ISSUE
A 0			2011-12-22
Drawn	Checked	Reviewed	Approved

RONDA BATTERY CO.LTD

Add /Block C & D,Shachongwei Industrial
Zone,Huangzhuang,Jianshe Third
Road,Jiangmen,Guangdong,China

Tel /86-750-3287188 3287189

Fax /86-750-3287198 3287199 P.C. /529000

http:// www.ronda-battery.com

E-mail/ ronda@ronda-battery.com

Notice: If the document wasn't signed and stamped, the information (subject to change without prior notice) contained in this document is for reference only and should not be used as a criterion for product guarantee or warranty.

IFR18650-1500mAh

1. SCOPE

The specifications governs the performance of the following **RONDA** LiFePO₄ Cylindrical cell and its battery pack. (Refer to the attached figure 1)

Rated capacity: **1500mAh**

Designation: IFR18650 (*D*: 18.3⁰_{-0.7}mm *H*: 65.5⁰_{-1.5}mm)

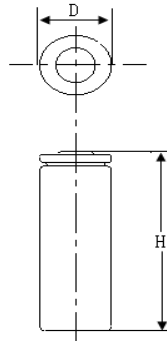

Figure 1- Jacketed LiFePO₄ cylindrical cells

2. DATA OF BATTERY PACK

The data of battery pack, including voltage and weight, is almost equivalent to the multiple numbers of the relevant single cells.

Example: Battery pack consisting three single cells

Nominal voltage of single cell = 3.2V

Nominal voltage of battery pack = 3.2V×3 = 9.6V

3. RATINGS

Table 1 - Ratings of the cells

Description	Unit	Specification	Remark
Nominal Voltage	V	3.2	Single cell
Max. Charge Voltage	V	3.7	Single cell
Discharge cut-off Voltage	V	2.0	Single cell
Max. constant charge current	mA	1500(1.0ItA)	/
Max. constant discharge current	mA	3000(2.0ItA)	/
Rated Capacity	mAh	1500	Charge with 0.2ItA to 3.7V, then charge with constant voltage till the charge current is less than 0.01ItA , and rest for 60 min, discharge with constant current 0.2ItA to 2.0V.
Operation Temp.	°C	Charge:0~60 Discharge:-10~45	/
Storage Temp.	°C	-10~45 within 1 month	/
Weight	g	About 40	For reference only
Storage Voltage	V	3.20~3.40	

IFR18650-1500mAh
4. PERFORMANCE AND TEST METHOD

Standard charge method: Charge with constant current 0.2ItA to 3.7V/cell, and then charge with constant voltage 3.7V, when the charge current is less than 0.01ItA, stop charging.

Standard testing condition :

Temp. : 20±5°C

Relative Humidity : 65±20%RH (Unless otherwise stated)

Table 2 – Performance and test methods ^b

Test Item	Unit	Specification	Test Conditions	Remarks	
Discharge performance	20 °C ^a	h	≥5	After Standard Charge, stored for 1-2 hrs, then Discharge with 0.2ItA to 2.0V	Can be recycled for 5 times
	-10°C	h	≥3	After Standard Charge, stored for 2h in -10±2°C, then discharged with 0.2ItA to 2.0V.	/
	55°C	h	≥4.5	After Standard Charge, stored for 2h in 55±2°C, then discharged by 0.2ItA to 2.0V.	/
Charge (capacity) retention	h/min	≥4h15min	After Standard Charge, stored on open circuit for a period of 28days in 20±5°C, then discharged with 0.2ItA to 2.0V.	/	
Endurance in cycles	cycle	≥1000	Discharge with 0.2ItA to 2.0V, charge with 0.2ItA to 3.7V, then charge with 3.7V till the charge current less than 0.01ItA, stored for 10min, and move to next cycle, cycles should be repeated until the discharge capacity is less than 80% of normal capacity for three times.	20±2°C	
Internal resistance	mΩ	≤80	50% Charged ,to measure in AC 1000Hz (20±2)°C	/	

4.2 Safety performance

Test Item	Specification	Test condition
Overcharge test	No fire, No explosion	Discharge with 0.2ItA to 2.0V, charge with 3ItA to 5.0V, when the constant voltage get to 5.0V the current is close to 0, last for 30min.
Over-discharge test	No fire, No explosion	After Standard charge, then discharge with 0.2ItA to 2.0V/cell, and then keeps on discharging for 24h loaded with 30 Ω.
Heat Impact test	No fire, No explosion	Standard charge first, then put the battery in the hot chamber, the temp. of chamber increased by 5±2°C every min. till 130±2°C keep for 10min.

IFR18650-1500mAh
4.3. Reliability Performance

Test Item	Specification	Test condition
High Temp. test	Electric performance and appearance are free from affected	Put the full charged battery in 70°C for 2 hours
Low temp. test	Electric performance and appearance are free from affected	Put the full charged battery in -10°C for 2 hours , then stored in room temp. for 3 hours
High Temp & High Humidity test	Electric performance and appearance are free from affected, including package.	Put the full charged battery in the chamber of 40±2°C 90-95%RH for 48 hours, then stored in 20±5°C for 2 hours

5. CONFIGURATION, DIMENSIONS AND MARKINGS

Please refer to the attached drawing.

6. EXTERNAL APPEARANCE

The cell/battery shall be free from cracks, scars, breakage, rust, discoloration, leakage nor deformation.

6. Protection function requirement

The cell/battery shall be free from cracks, scars, breakage, rust, discoloration, leakage nor deformation.

7. Protect requirement of battery

When Li-ion rechargeable battery is working under voltage/current which is higher than the specification stipulated, the electrolyte may be decomposed, which will affect the safety performance of the battery; the battery performance will be worsen if its voltage lower than 1.0V. In order to avoid overcharging, over-discharging or over-current , please use right charger to charge the battery.

To make sure safety, the charger and protect circuit should comply with following requirement:

Object	Item	Requirement	Remarks
Charger	Charge cut-off Voltage	(3.700~4.200)±0.049V	/
Protect Circuit (For reference only)	Overcharge protect Voltage	(3.700~4.200)±0.025V	/
	Overcharge recover Voltage	(3.700~4.200)±0.050V	/
	Discharge cut-off Voltage	2.0±0.10V	/
	Over-discharge protect Voltage	2.0±0.08V	/
	Over-discharge recover Voltage	2.0±0.10V	/
	Over current protect Value	2.0±0.2A	/

Note : The above parameter is for reference only, customers could decide to adopt or change according to the practical situation.

IFR18650-1500mAh**8. Period of warranty**

12 months from manufacture date

9. Disclaimer clause

Fire or explosion will happen in case misuse of battery. So please comply with Ronda specification and caution in the document. Ronda will take no responsibility for any accident when the cell is used under other conditions than those described in this Document.

10. Caution in use

- 1) Do not immerse the cell in water, it should be kept in dry;
- 2) Do not use/expose the cell to extreme heat or flame;
- 3) Use the special Li-ion charger to charge the cell;
- 4) Do not reverse the polarity of the cell for any reason;
- 5) Do not connect cell to the plug socket or car-cigarette-plug;
- 6) Do not throw the cell into heater or fire;
- 7) Do not connect the cell with metal directly;
- 8) Do not handle or store with metallic like necklaces, coins or hairpins, etc.
- 9) Do not strike the cell by hammer or tread it.
- 10) Do not make the direct soldering onto a cell or drive a nail into the cell;
- 11) Do not use or leave the cell in high temp. (Under the blazing sun or in heated car by sunshine),to avoid fire, disabled or life shorter of the cell;
- 12) Do not use the cell under strong static or magnetic field, to avoid destroying of the protect device;
- 13) If the electrolyte came into the eyes, do not rub, you should wash with water and contact a doctor at once;
- 14) If find any peculiar smell, heat, color change, distortion of the cell or there is any abnormality in using, storing or charging process, you should take it from the device or charger and stop its use;
- 15) To avoid bad contact or function disabled, please use a dry cloth to clean the battery if it is dirty;
- 16) Wasted cells should be packed with a insulated paper, to avoid fire or explosion.

IFR18650-1500mAh

Base Data:

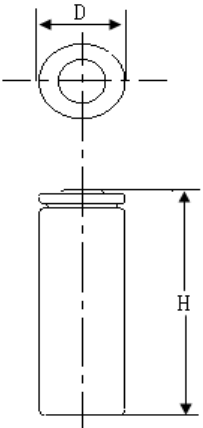
	
D	18.3 ⁰ _{-0.7} mm
H	65.5 ⁰ _{-1.5} mm

Nominal voltage		3.2V	
Capacity comparison(mAh)		0.2I _t A	1.0I _t A
		1500	1425
Weight(g)		40	
Internal Impedance at 1000Hz (After Charge;mΩ)		≤80	
Charge current	Standard	300mA	
	Fast	1500mA	
Charge time	Standard	/	
	Fast	/	
Ambient Temperature	charge	Standard	0~+45°C
		Fast	+10~+45°C
	Discharge		-20~+60°C
	Storage		-20~+35°C

Electric performance :

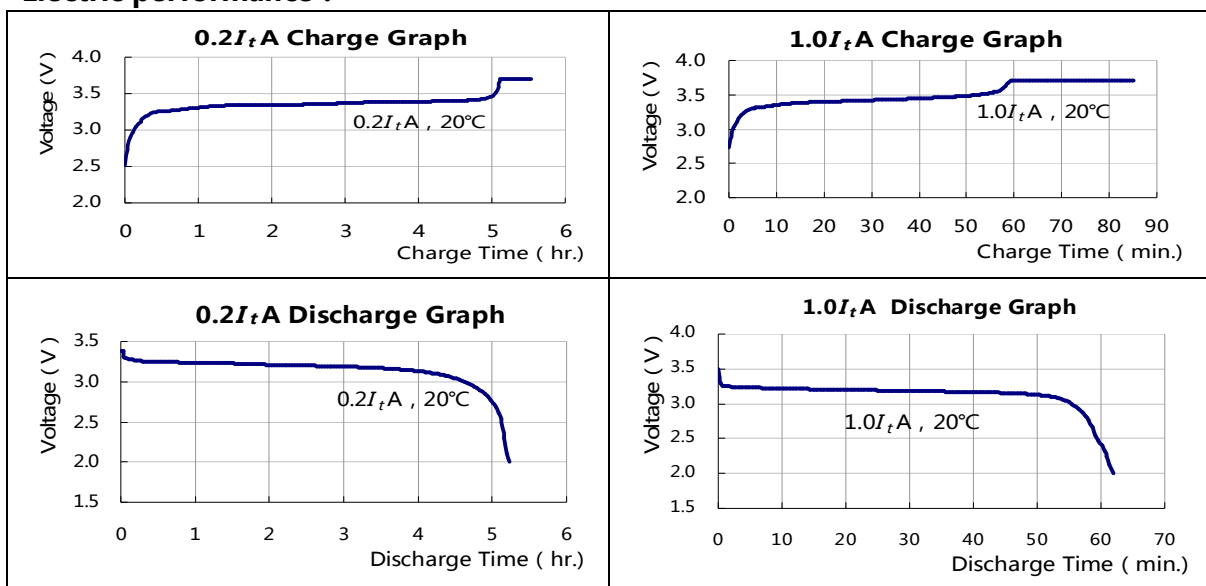

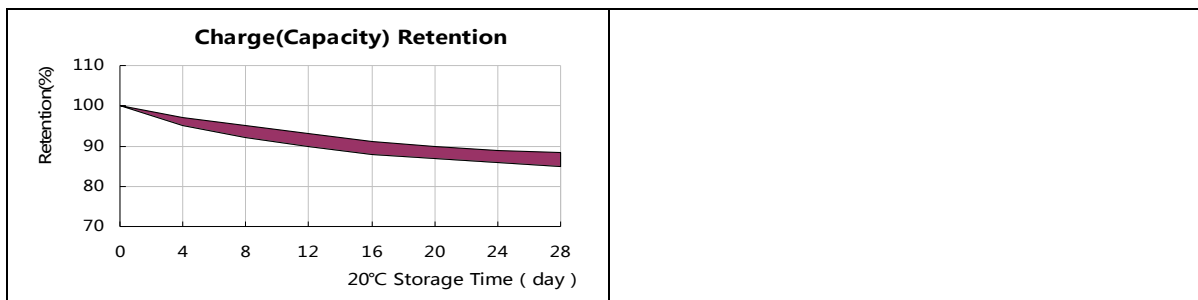

Notice: If the document wasn't signed and stamped, the information (subject to change without prior notice) contained in this document is for reference only and should not be used as a criterion for product guarantee or warranty.



S/RONDA1403-1
产品规格书

文件名称： 圆柱型磷酸铁锂电池规格书
 型 号： IFR18650-1500mAh
 编 号： S/RONDA1403-1
 版 次： A 0
 日 期： 2011年12月22日

版 次	修 改 内 容		生 效 日 期
A 0			2011-12-22
草 拟	审 核	复 核	批 准

江门市朗达电池有限公司

地址 / 广东省江门市建设三路篁庄沙冲围工业区C、D栋

电话 / 86-750-3287188 3287189

传真 / 86-750-3287198 3287199

邮编 / 529000

http:// www.ronda-battery.com

E-mail/ ronda@ronda-battery.com

如果文件没有签名并盖章，本文件中包含的信息仅供参考，不应被用来作为产品提供保证或担保的基准。（如有变更，恕不另行通知）



IFR18650-1500 毫安时

1. 范围

本规格书适用于下述的朗达牌圆柱型磷酸铁锂电池单体及电池组的全部性能指标。

额定容量: 1500mAh

电池型号: IFR18650 ($D: 18.3^{0}_{-0.7}mm$ $H: 65.5^{0}_{-1.5}mm$)



图 1 带防护外套的圆柱型锂离子可充单体电池

2. 组合电池的指标

组合电池的电压、重量等数据，近似等于单体电池数与对应值之乘积。

例如：组合电池包括三个单体电池

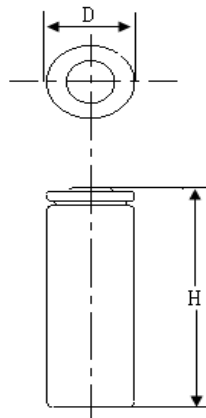
单体电池的额定电压=3.2V

则电池组的额定电压=3.2V×3=9.6V

3. 基本性能

表 1 电池的额定性能

项目	单位	指标	备注
标称电压	V	3.2	单体
最大充电电压	V	3.7	单体
最小放电终止电压	V	2.0	单体
最大持续充电电流	mA	1500 mA (1.0ItA)	/
最大持续放电电流	mA	3000 mA (2.0ItA)	/

额定容量	mAh	1500	0.2ItA 充电至 3.7V, 再恒压充电至充电电流小于 0.01ItA, 搁置 60min, 0.2ItA 恒流放电到 2.0V。
工作温度范围	°C	充电: 0~60 放电: -10~45	/
储存温度	°C	一个月内-10~45	/
重量	g	约 40	参考值
储存电压	V	3.20~3.40	



IFR18650-1500 毫安时

4. 电池性能与测试方法

完全充电条件：恒流 0.2ItA 充电至 3.7V，再恒压 3.7V 充电至充电电流小于 0.01ItA

标准测试环境：

温度：20±5°C

相对湿度：65±20% (除非另外要求)

4.1 电性能

测试项目	单位	标准	测试方法	备注	
放电性能	20°C ¹⁾	h	≥5	在环境温度为 (25±2)°C 条件下完全充电后搁置 1 - 2 小时, 以 0.2ItA 放电至 2.0V。	可循环五次
	-10°C	h	≥3	完全充电后将电池置于 (-10±2)°C 条件下恒温 2h 后, 以 0.2ItA 电流恒流放电至 2.0V。	/
	55°C	h	≥4.5	完全充电后将电池置于 (55±2)°C 条件下恒温 2h 后, 以 0.2ItA 电流恒流放电至 2.0V。	/
荷电保持率	h/min	≥4h15min	完全充电后, 开路搁置 28 天(20±5°C), 随后以 0.2ItA 电流恒流放电至 2.0V。	/	
循环寿命	Cycle	≥1000	以 0.2ItA 电流恒流放电至 2.0V, 再以 0.2ItA 电流恒流充电至 3.7V, 然后恒压 3.7V 充至电流小于 0.01ItA 搁置 10min, 以 0.2ItA 电流恒流放电至 2.0V 放电结束后, 搁置 10min, 再进行下一充放电循环, 直至连续三次放电容量小于 80% 的额定容量 (C ₅ mAh) 为止。	/	
内阻	mΩ	≤80	环境温度 (20±2)°C, 电池带电 50% 状态时 1KHZ 交流电测得的内部阻抗。	/	

4.2 安全性能

测试项目	标准	测试方法	备注
过充测试	不爆炸, 不起火	电池以 0.2ItA 电流恒流放电至 2.0V, 再以 3ItA 电流和限制电压 5.0V 的充电制度充电, 至 5.0V 恒压电流接近 0, 持续 30 分钟。	/
过放测试	不爆炸、不起火	完全充电后, 在 (20±5)°C 环境温度条件下, 以	/

		0.2ItA 电流恒流放电至 2.0V 后，外接 30 Ω负载电阻放电 24h。	
热冲击试验	不爆炸、不起火	将充满电的电池放在重力对流或循环空气的烘箱中进行加热，烘箱温度以每分钟 (5±2) °C 的速度上升到 (130±2) °C 保持 10 分钟。	/



IFR18650-1500 毫安时

4.3 可靠性能

测试项目	标准	测试方法	备注
高温试验	电性能、外观不受影响	将充满电的电池置于 70 °C 环境中 2 小时。	/
低温试验	电性能、外观不受影响	将充满电的电池置于 -10°C 环境中 2 小时后 再室温中搁置 3 小时。	/
高温高湿试验	电性能、外观不受影响， 包括包装。	将充满电的电池放入 (40±2) °C、相对湿度为 90 - 95% 的恒温恒湿箱中搁置 48 小时，取出电池在环境温度为 (20±5) °C 的条件下搁置 2 小时。	/

5. 电池尺寸和标志

参见附图

6. 电池外观

电池表面无划伤、脏点、变形、漏液、鼓气等缺陷。

7. 电池保护功能要求

当锂离子蓄电池在高于允许电压或电流情况下工作，电解液可能会分解，这样会影响到电池的安全性能；而电池的电压低于 1.0V 时，电池性能会恶化。因此，电池在使用过程中，应使用专用的充电器对电池进行充电，以防止电池出现过充、过放和过流现象。

为确保安全，充电器和保护电路应符合以下要求：

单元	项目	要求	备注
充电器	充电终止电压	(3.700~4.200)±0.049 V	/
保护电路 (供参考)	过充保护电压	(3.700~4.200)±0.025 V	/
	过充恢复电压	(3.700~4.200)±0.050 V	
	放电终止电压	2.0±0.10 V	
	过放保护电压	2.0±0.08 V	

	过放恢复电压	2.0±0.10 V	
	过流保护值	2.0±0.2 A	

注：上表中的参数仅参考，客户可根据实际情况选择是否采用或变更。

8. 电池保质期限

从出厂日期（喷码）开始 12 个月。



产品规格书

IFR18650-1500 毫安时

9. 产品责任

由于误用会引起电池过热，发生火灾或爆炸。因此，请严格遵守本公司规格书和文件后面的电池使用注释。除按规格书要求操作造成的事故外，本公司对由于误用所造成的任何事故概不负责。

10. 使用注意事项

- 1) 严禁将电池浸入水中，应于阴凉干燥的环境中保存；
- 2) 禁止将电池置于高温热源（如火、加热器等）旁使用或搁置；
- 3) 充电时请选用锂离子电池专用充电器；
- 4) 严禁颠倒正负极使用电池；
- 5) 严禁将电池直接接入电源插座；
- 6) 禁止将电池掷于加热器或火中；
- 7) 禁止用金属直接连接电池正负极短路；
- 8) 禁止将电池与金属，如发卡、金属首饰等一起运输或储存；
- 9) 禁止敲打、投掷或踩踏电池；
- 10) 禁止直接焊接电池和用钉子及其他利器吃穿电池；
- 11) 禁止在高温下（如炙热的阳光下或炎热的汽车中）使用或放置电池，以免造成电池过热、起火或功能失效、寿命缩短。
- 12) 禁止在强静电和强磁场条件下使用电池，以免破坏电池安全保护装置，带来安全隐患；
- 13) 如电池泄露，不小心使电液进入眼睛，请不要揉擦，立即用清水冲洗眼睛，并立即求助医护治疗。

14) 如电池发出异味、发热、变色、变形或使用、贮存、充电过程中出现任何异常，应立即从装置或充电器中取出并停止使用。

15) 电池脏污，适用前应用干布抹净，以免导致接触不良或功能失效；

16) 废弃电池应用绝缘纸包住电极，以防起火或爆炸。



IFR18650-1500 毫安时

基础数据：

<i>D</i>	18.3 ⁰ _{-0.7} mm
<i>H</i>	65.5 ⁰ _{-1.5} mm
<i>b</i>	
<i>a</i>	

标称电压		3.2V	
容量对比(mAh)		0.2ItA	1.0ItA
		1500	1425
重量 (g)		40	
内阻 (在 1000Hz 下) (充电后; mΩ)		≤80	
充电电流	标准	300mA	
	快速	1500mA	
充电时间	标准	/	
	快速	/	
使用温度	充电	标准	0~+45°C
		快速	+10~+45°C
	放电	-20~+60°C	
	贮存	-20~+35°C	

电气性能：

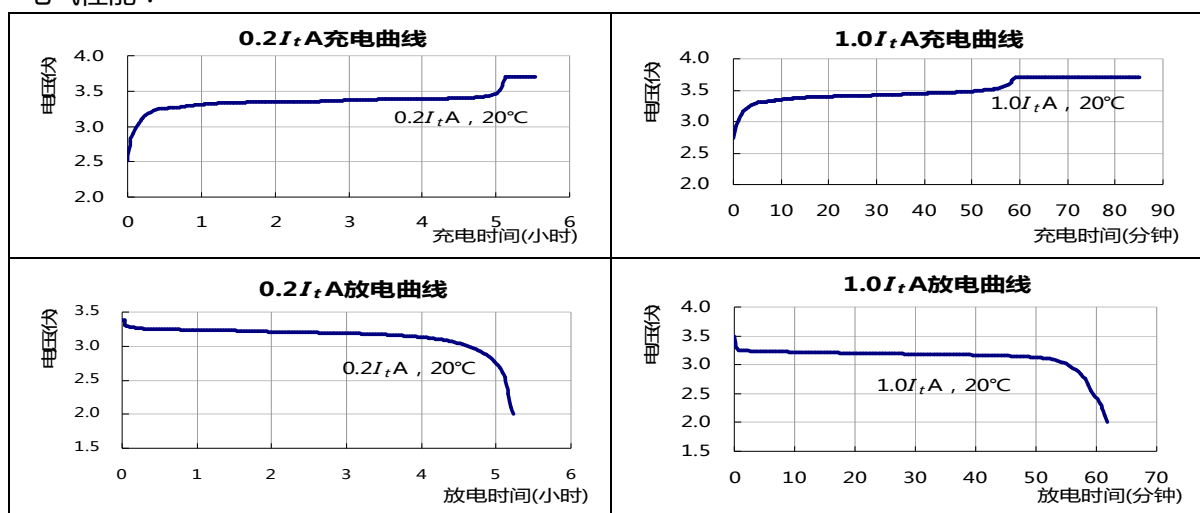

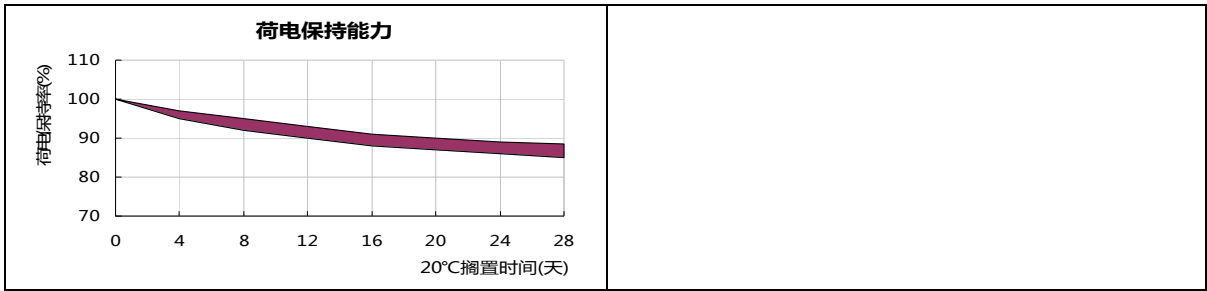

注：本公司保留该规格书的修订权。（如有变更，恕不另行通知。）

本文件中包含的信息仅供参考，不应被用来作为产品提供保证或担保的基准。

S/RONDA1403-1